

# SUB-COMPACT & COMPACT SWEEPERS

Powerful, highly flexible  
sweeping and cleaning vehicles for  
any urban environment.

NEW

## UPGRADES FOR 2026

See what's new inside this brochure



## RAVO R1, R2 & E2

ENVIRONMENTALLY-FOCUSED SUB-COMPACT & COMPACT ROAD SWEEPING SOLUTIONS



# WELCOME TO RAVO

## Industry Leading Road Sweeping & Cleaning Solutions

With a long and pioneering history in the industry, RAVO is a leading manufacturer of high-quality compact road sweeping solutions spanning from 1 to 5 cubic metre hopper capacities. RAVO vehicles are durable and reliable industry standouts designed with operator efficiency, comfort and safety in mind.

Partnered with a strong global dealer network and an expert Parts & Service team, RAVO is proud to offer our customers a complete range of products and services.



### The Leader in Compact Sweepers

The **R1** and **R2** are the established first choice sub-compact and compact sweepers for municipalities across the world. Joining the range in 2023, the **all-electric E2** revolutionizes the expectations of electric sweeping – spearheading innovative energy management and unrivalled performance benefits.

Our machines are powerful, and so  
are our partnerships

To find your local RAVO  
dealer, visit our website:  
[ravo.fayat.com](https://ravo.fayat.com)



# RAVO R1

Dedicated sweeping performance for the city

Built to work hard in the heart of the city, RAVO's R1 sub-compact sweeper combines powerful performance with exceptional manoeuvrability to reach areas inaccessible to others.

- **Agile in every environment.** An articulated cabin and compact design makes it easier to clean in tight spaces. Its inner turning radius is only 735 cm.
- **Operator focused driving experience.** The R1's cabin is the most spacious in its category and has been designed to empower the operator. It features an ergonomic layout, 360° vision, 7" display screen, air conditioning, and more.

## Unrivalled sub-compact performance

- Automatic brush and water start/stop system, as standard.
- Dedicated sweeper with a robust stainless steel hopper.
- Dynamic braking system.
- Four wheel drive system that offers excellent climbing ability.
- Oscillating suspension on each wheel.
- A wide range of accessories and options.



Your choice of Stage V engines:

- > 1.5L Diesel (KUBOTA V1505-E4B)
- > 1.6L Essence (KUBOTA G1605-E3)

# R1

**SIZE:** 2.4 tonnes GVW

**SPEED:** 0 – 25 km/h

**CATEGORY:** 1 m<sup>3</sup>

**WATER TANK CAPACITY:** 140 L

**SWEEP WITH:** 1380 – 1800 mm

**WHEELS:** Large 14 inch wheels

## For a cleaner environment

The R1 has three preset modes: **Standard**, **EcoMode** and **BoostMode**. Using EcoMode allows the operator to save up to 50% in fuel, reduces noise pollution and preserves the life of your sweeper.



A reduction in clean water consumption.



Low particle emissions – 4 stars in the EU PM2.5/10 test.



High end-of-cycle recyclability.



ISO 9001, ISO 14001 and ISO 45001 certifications – guaranteeing that our manufacturing process takes the environment into account.



# RAVO R2

## Setting the standard in urban cleanliness

Class-leading suction and sweeping performance combines with exceptional comfort and agility – the R2 excels in any urban environment.

- **Unrivalled suction performance in the 2m<sup>3</sup> segment.** The unique suction line is designed with a 250mm straight suction pipe and a 13,000 m<sup>3</sup>/h turbine to optimise airflow. The R2 sets the standard for vacuum performance.
- **Patented push/pull sweeping system.** Clean the most difficult to reach areas with a unique brush deployment and independently controlled brushes. The R2 reaches up to 2450mm (or up to 2900 mm with third brush option).
- **Agile in the city.** A short overhang and 4-/2-wheel steering, with patented auto-steer system, helps the operator sweep in tight spaces. This system also makes the transition from sweeping to transit easy.



## An industry standout

- Operates in 2- and 4-wheel steering mode.
- Start and stop sweeping functions with the press of a single button.
- A comfortable cabin with 360° panoramic view.



Straight suction pipe.



Push/pull sweeping system.

# R2

**SIZE:** 5.3 tonnes GVW

**SPEED:** 25, 30, 40, 45 or 50 km/h

**CATEGORY:** 2 m<sup>3</sup>

**CLEAN WATER TANK:** 300 L (Up to 540 L with option)

**WATER RECYCLE OPTION:** 200 L

**SWEEP WIDTH:**

- > 1280 – 2450 mm (Standard)
- > Up to 2900 mm (with Third Brush)

We offer five engine options that deliver powerful low-speed performance, while keeping the environment in mind.

- > Kubota V3800 Stage V / Tier 4
- > VM R754 Euro 6 Step D (HVO compatible)
- NEW** > VM R754 Euro 6 Step E (HVO compatible)
- > Kubota Stage IIIA\*
- > Kubota WG 3800 Essence Stage V
- > Kubota Essence Stage V Éthanol



## A flexible range of front tools

Tackle a wide range of applications with the R2's flexible front tool platform.



### Third Brush

> The R2's third brush option extends sweep coverage to an impressive 2900 mm. It is also perfect for weed ripping applications, without the need to use harmful chemicals.



### High Pressure Spray Bar

> For dedicated street washing, the front spray bar attachment delivers exceptional coverage for in-depth cleaning of the road surface.



### Scrubbing Deck

> A dedicated scrubbing head, with three powerful brushes and an integrated detergent tank, is perfect for renovating any type of road surface.



### Winter Maintenance Equipment

> The R2 offers a number of flexible front tools to help customers tackle winter maintenance including a snow brush, snow blade and gritting unit.



\*Available for non-EU Markets

**NEW**

# UPGRADES FOR 2026

Model Year Change enhancements for the RAVO R2.

## New Seats & Storage

New driver seat for enhanced comfort and operation, new passenger seat (with suspension) and in-cabin storage box.

SEATS: STANDARD, STORAGE BOX: OPTIONAL

## New Hopper Deflector Plate

Increased efficiency for debris flow and increased filling capacity within the sweeper's hopper.

INCLUDED AS STANDARD



## Improved Cab Entry Step

Re-designed cab entry step for easier, safer access to the RAVO R2's cabin.

INCLUDED AS STANDARD

## Auto Brush/Water Start-Stop

Automatic brush/water start-stop system to reduce brush wear and water consumption.

INCLUDED AS STANDARD

## New Lights & Work Lights

New lights and work lights on the front and rear of the sweeper for increased visibility.

INCLUDED AS STANDARD



## New Recycling Grid System

Foldable design for improved access for cleaning and accessibility to the decantation valve.

INCLUDED AS STANDARD



## VM Euro 6 - Step E Engine

Now available with a VM Euro 6 - Step E engine, the cleanest diesel engine on the market.

AVAILABLE AS AN OPTION



# R1/R2 TECHNICAL SPECIFICATIONS

## RAVO R1

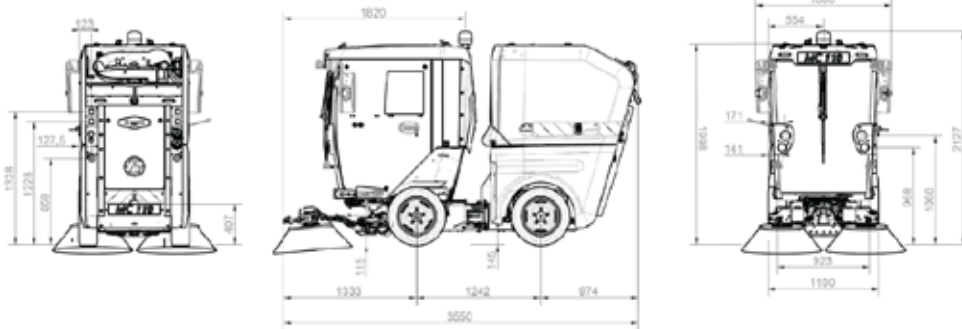

### Steering

<b>Steering</b>	Articulated
<b>Turning Radius (Internal)</b>	735 mm
<b>Turning Radius (Between Sidewalks)</b>	1875 mm
<b>Turning Radius (Between Walls)</b>	2175 mm

### Brakes

<b>Front</b>	Dynamic Drum Brakes - Integrated into the Drive Motors
<b>Parking</b>	Multidisc Brakes with Lack of Pressure Integrated into the Drive Motors

### Weights

<b>Tare Weight (Option Dependent)</b>	1900 kg
<b>GVW</b>	2400 kg

### Speeds

<b>Transit Speed</b>	0 - 25 km/h
<b>Engine Speed (Transit Mode)</b>	3000 rpm
<b>Work Speed</b>	0 - 7 km/h
<b>Engine Speed (Work Mode)</b>	1600/1900/2200 (diesel) 1250/1600/1900 (gasoline)

### Transmission

<b>Wheel Drive</b>	4
<b>Drive</b>	Hydrostatic
<b>Gradeability</b>	Up to 30%

### Capacities

<b>Fuel Tank</b>	45 L
<b>Clean Water Tank</b>	140 L
<b>Recycling System</b>	100 L
<b>Hydraulic Tank</b>	45 L

### Suspension

<b>Front &amp; Rear</b>	Independent Wheels Suspended on Leaf Springs
-------------------------	--

### Tyres

<b>Front</b>	175/65 R14
<b>Rear</b>	175/65 R14

## RAVO R2

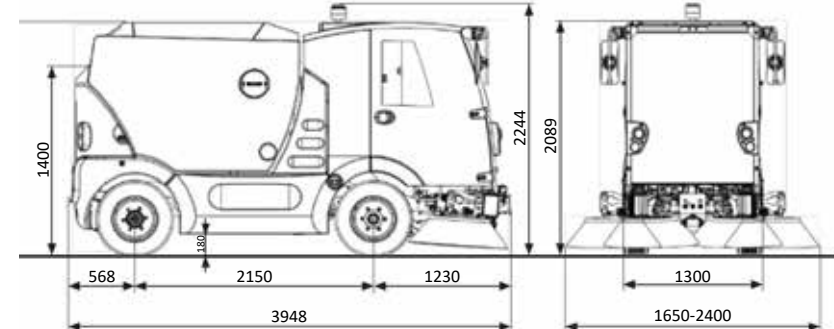

### Steering

<b>Steering</b>	2 or 4 Wheel Steer with Automatic Realignment of Rear Axle in Transit
<b>Turning Radius (Curb to Curb)</b>	3150 mm
<b>Turning Radius (Wall to Wall)</b>	3700 mm

### Brakes

<b>Front</b>	Disc Brakes with Dual Braking System
<b>Parking</b>	Hydraulic Brakes and Rear Disc Brakes (Optional)

### Weights

<b>GVW</b>	5300 kg
<b>Max. Weight on Front Axle</b>	2750 kg
<b>Max. Weight on Rear Axle</b>	2750 kg

### Speeds

<b>Transit Speed</b>	25 - 50 km/h
<b>Work Speed</b>	0 - 15 km/h
<b>Engine Speed (Work Mode)</b>	1400 - 2000 rpm
<b>Gradeability</b>	Up to 28%

### Capacities

<b>Fuel Tank</b>	70 L
<b>Clean Water Tank</b>	300 L
<b>Additional Clean Water Tank</b>	240 L
<b>Water Recycling Option</b>	200 L

### Suspension

<b>Front &amp; Rear</b>	Leaf Springs
-------------------------	--------------

### Tyres

<b>Front</b>	225/65 R16 C
<b>Rear</b>	225/65 R16 C



**RAVO**  
FAYAT GROUP

100% ELECTRIC  
100% PERFORMANCE  
LOW NOISE

E2

# THE AWARD-WINNING RAVO E2

Since its groundbreaking launch in 2023, the revolutionary RAVO E2 has garnered international acclaim for its pioneering approach to electrification. Recognised by several prestigious award bodies, the RAVO E2 continues to set new standards in sustainable innovation. **Below is a selection of the accolades it has proudly received to date:**



reddot winner 2024

Winner in the **Product Design** and **Product Innovation** categories - 2024.



**Silver Medal** in the **Commercial Vehicle Category** - 2024.



**Fleet Product of the Year** - 2025.



Green Good Design  
2025 Winner

**GREEN GOOD DESIGN™ Award**  
Winner - 2025.

# RAVO E2

100% performance, 100% electric,  
0% emissions - **the revolutionary E2**

To optimize performance, minimize environmental impact and guarantee great working autonomy, **the E2 revolutionizes energy management:**



Optimised Energy  
Consumption



Water Saving



TCO Reduction



Low Noise

Renowned RAVO quality, exceptional suction performance and the environmental protection we all need. The E2 goes beyond electrification with the latest developments to deliver efficiency, performance and operator comfort.

- **Choice of 48 or 64 kWh battery.** This means you can choose the right size (and cost) for your operation.
- **Autonomy.** Finish your shift without worrying about recharging through the optimization of consumption and energy management.
- **Built for the city.** The E2 delivers emission-free, low-noise sweeping – making it ideal for any urban environment.



# E2

**BATTERY TYPE:** Forsee Power Lithium-ion (NMC)

**BATTERY CAPACITY:** 48 or 64 kWh

**SPEED:** 25 - 50 km/h

**SUCTION POWER:** 13,000 m<sup>3</sup>/h

**SWEEPING WIDTH:** 1280 - 2450 mm

**TURNING RADIUS:** 3150 mm (curb to curb)



The RAVO E2 has been awarded R100 and R10 certification on both the battery pack and the complete sweeper, in accordance with Europe's most demanding automotive safety standard, guaranteeing the exceptional quality of the battery cells.

**R100-1:** Safety Vehicle

**R10:** Electromagnetic Compatibility

**R100-2:** Safety Battery

**UN 38.3:** Transportation of the Battery

## Patented Innovations

### Intelligent Energy Management

The E2's philosophy is to deliver energy only when it is required. The machine's electro-hydraulic architecture has been designed to optimise energy consumption for exceptional autonomy.



### Redesigned Suction System

The suction system has been designed to reduce power losses and the new suction mouth increases peripheral air velocity. In addition to this, the turbine also produces superior suction performance and has an intelligent self-adjustment feature.



### Automatic Brush/Water Start-Stop System

When you stop while working (for example, at a red light), the E2 automatically stops sweeping and halts the delivery of water to the water jets – this saves energy and water to extend on-station time.



### Swappable Battery System

The E2 allows you to exchange its battery for a freshly charged one at the end of a shift, providing greater flexibility for workload organization. This option removes range anxiety and extends battery life by removing the need for fast charging.



NEW

# UPGRADES FOR 2026

Model Year Change enhancements for the RAVO E2.

## Electrification Enhancements

The RAVO E2's revolutionary approach to energy management just got even better. Discover the latest electrification enhancements available with the RAVO E2 below:

### SMART CHARGING *(Included as Standard)*

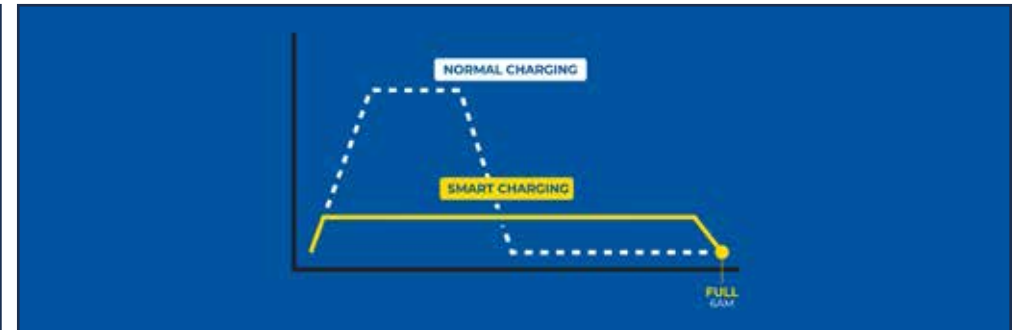

- > The RAVO E2 is now available with an innovative Smart Charge feature - delivering self-adjusting charging and enabling deferred charging solution.
- > The E2 will spread the charging current until the start of the next shift to reduced the amount of 'instant power' required from the infrastructure.
- > This preserves the RAVO E2's battery life and delivers a positive impact on the TCO (by charging in off-peak times).

### CABIN PRE-CONDITIONING *(Included as Standard)*

- > While the RAVO E2 is on charge, the cabin is pre-heated or pre-cooled automatically before the start of the next shift. This delivers an enhanced operator experience at the start of the shift, as well as increasing battery autonomy by using the energy to pre-condition the cabin while charging.



# Performance Advancements

To optimize performance, the RAVO E2 offers a number of performance enhancements for 2026. These include:

## Non-Flex Version

The Non-flex E2 is ideal for operators looking to complete any sweeping applications.

AVAILABLE AS STANDARD

## Easier Grid Cleaning

A new handle on the filter casing draw makes cleaning easier, while also preserving the machine's lifespan.

INCLUDED AS STANDARD



## New Hopper Deflector Plate

Increased efficiency for debris flow and increased filling capacity within the sweeper's hopper.

INCLUDED AS STANDARD

## New Lights & Work Lights

New lights and work lights on the front and rear of the sweeper for increased visibility.

INCLUDED AS STANDARD

## Improved Water Capacity

The clean water capacity of the RAVO E2 can now reach up to 540L with an additional water tank.

AVAILABLE AS AN OPTION



## New Recycling Grid System

Foldable design for improved access during cleaning of the recycling area and the decantation valve.

INCLUDED AS STANDARD



NEW

# UPGRADES FOR 2026

Model Year Change enhancements for the RAVO E2.

## Operator-Focused Updates

For 2026, the RAVO E2 is improving to offer even greater useability and efficiency to the operator. New enhancements include:

### **Improved Cab Entry Step** *(Included as Standard)*

- > The RAVO E2 features a re-designed cab entry step for easier, safer access to the operator's working environment.

### **New Seats** *(Included as Standard)*

- > The E2 has a new drivers seat for enhanced operator comfort and safety, as well as a new passenger seat with suspension.

### **Heated Floor Mat** *(Available as an Option)*

- > The RAVO E2 is now available with a heated floor mat. This heating solution is more energy efficient than traditional blowers, creates a warm working environment for the operator and helps to reduce condensation on the windscreen.

### **Acoustic Vehicle Audible System (AVAS)** *(Included as Standard)*

- > The RAVO E2 now comes equipped with an Acoustic Vehicle Audible System (AVAS) to support safe operation in urban environments. This system emits a modern, lightweight sound while the sweeper is in motion – whether travelling or actively sweeping – ensuring pedestrians and nearby traffic are aware of its presence. For added safety and convenience, this device is also integrating dumping alarm function with with settable white sound. Additionally, an optional 'ding-dong' warning bell can be installed inside the cabin, allowing the operator to manually alert pedestrians when necessary.

### **New Lights & Work Lights** *(Included as Standard)*

- > The RAVO E2 features new standard and working lights to improve the visibility of the sweeper, while also giving it a new look and feel.

### **Storage Box** *(Available as an Option)*

- > Inside the cab, operators have the option of a new storage box for storing tools and other items while working.



IMPROVED CAB ENTRY STEP



HEATED FLOOR MAT

# E2 TECHNICAL SPECIFICATIONS

## Steering

<b>Steering</b>	2 or 4 Wheel Steer with Automatic Realignment of Rear Axle in Transit
<b>Turning Radius (Curb to Curb)</b>	3150 mm
<b>Turning Radius (Wall to Wall)</b>	3700 mm

## Weight

<b>GVW</b>	5300 kg
<b>Maximum Weight (Front Axle)</b>	2750 kg
<b>Maximum Weight (Rear Axle)</b>	2750 kg

## Speeds

<b>Transit Mode</b>	Up to 50 km/h
<b>Work Speed</b>	0 - 15 km/h (0 - 7 km/h Optional)
<b>Gradeability</b>	Up to 28%

## Brakes

<b>Front</b>	Disc brakes with Dual Braking System
<b>Rear</b>	Disc Brakes

## Tyres

<b>Front</b>	225/65 R16 C
<b>Rear</b>	225/65 R16 C

## Suspension

<b>Front &amp; Rear</b>	Leaf Springs
-------------------------	--------------

## Dimensions

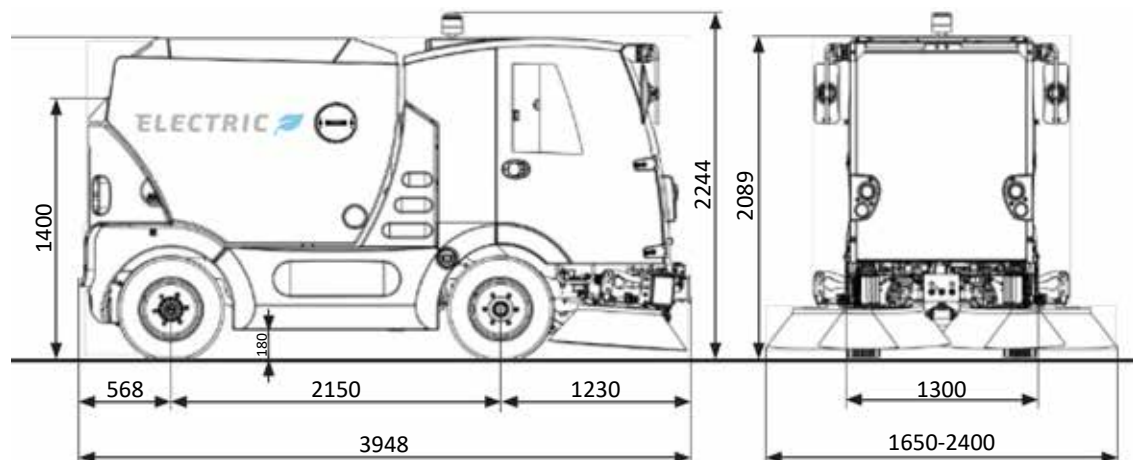

## Battery

<b>Battery Type</b>	Forsee Power Lithium-ion (NMC)	Forsee Power Lithium-ion (NMC)
<b>Capacity</b>	48 kW/h	64 kW/h
<b>Normal Voltage</b>	96 V	96 V
<b>Performance</b>	Completes a Full Shift*	Completes a Full Shift*
<b>Warranty</b>	3 Years or 4000 Hours	3 Years or 4000 Hours

## Drive System

<b>Max. Torque</b>	Up to 720 Nm
<b>Max. Power</b>	40 kW @ 1500 rpm (25 kms/hr) / 75 kW @ 2000 rpm (50 kms/hr)

## Charging

<b>Charger</b>	6 kW	18 kW
<b>Electric Network</b>	Three-Phase	Three-Phase
<b>Charging Times (48 / 64 kW)</b>	8h / 10h	2.5h / 3.5h
<b>Charge Type</b>	Type 2 - (CEI 62196 - 2)	32 A Tetrapolar
<b>Charge Location</b>	Internal	External



\*Depending on the user profile/charge usage/according to standard 15429-1

# OPERATOR FIRST

Performance, visibility & safety for all applications

At RAVO, our focus is on the operators behind the wheel.

With increased cabin comfort, unwavering safety standards and an ergonomic, innovative control panel for easy and efficient control of all sweeping functions, our vehicles deliver long-lasting performance that our operators can rely on every time.



## Next Generation Telematics.

The RAVO R2 and E2 are equipped with an onboard telematics system that collects 50 signals from the CANbus system, as well as collecting location data and delivering updates on sweeper route information.

As part of the telematics system, the operator has access to data from your Propulse dashboard, your own fleet management system, via an API connection. Discover more by scanning the QR code



# AFTER SALES SUPPORT

## Genuine RAVO parts

The best way to ensure your machine remains working in top condition is by always using Genuine RAVO Parts. With a high first time pick rate and dedicated parts facilities stationed around Europe, we'll have your parts to you as quickly as possible, wherever you are in the world.

## Class-leading service

RAVO understands that keeping your machine on the road is one of our most important jobs. That's why we prioritise a Dealer Network that's as powerful as our machines. Find your local dealer for more information about the service options available to you: [ravo.fayat.com](http://ravo.fayat.com)



myRAVO is a state-of-the-art online portal to help our dealers and customers keep every RAVO machine operating in peak condition. Features include:

- Access to the latest information on all RAVO machines.
- Technical documentation for all models.
- Access to warranty services.



The RAVO - SCARAB Academy sets the industry standard in dealer and customer training. The RAVO - SCARAB Academy strives to deliver the highest level of training, knowledge and skills to every participant to help them get the most from their sweeper.

We provide a comprehensive range of training courses specifically designed around our products that contribute to increased safety standards, increasing the uptime of each sweeper, and helping customers achieve greater cost efficiency.



**Flexible Sub-Compact & Compact road sweeping solutions:**

- New generation electric technology.
- Exceptional suction performance.
- Operator-first driving experience.
- Next generation telematics.

Discover the full RAVO range: [ravo.fayat.com](https://ravo.fayat.com)

Dealer

